

## GNSS Data Processing for High-Accuracy MADOCA-PPP using MAD-WIN and MADROID

Dinesh Manandhar

Center for Spatial Information Science

The University of Tokyo

Contact Information: [dinesh@csis.u-tokyo.ac.jp](mailto:dinesh@csis.u-tokyo.ac.jp)

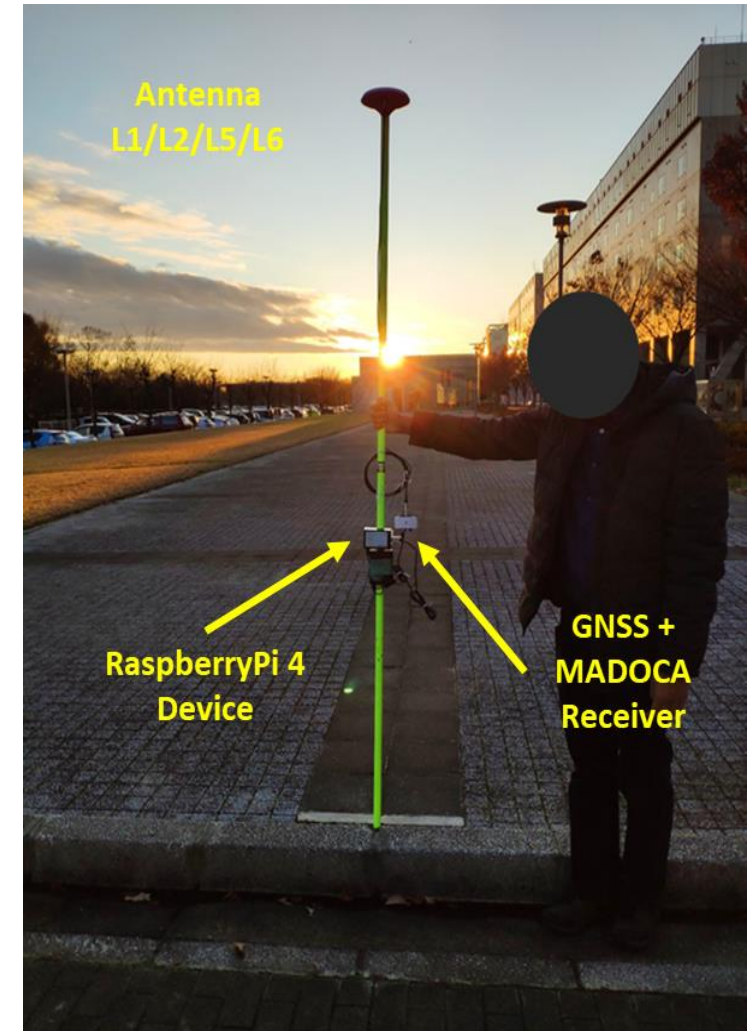

# Objectives

- Learn how to process GNSS data for MADOCA-PPP using
  - MAD-WIN
    - MADOCA PPP for Windows OS
  - MADROID Software
    - MADDOCA PPP for Android Device

# Position Accuracy and Errors

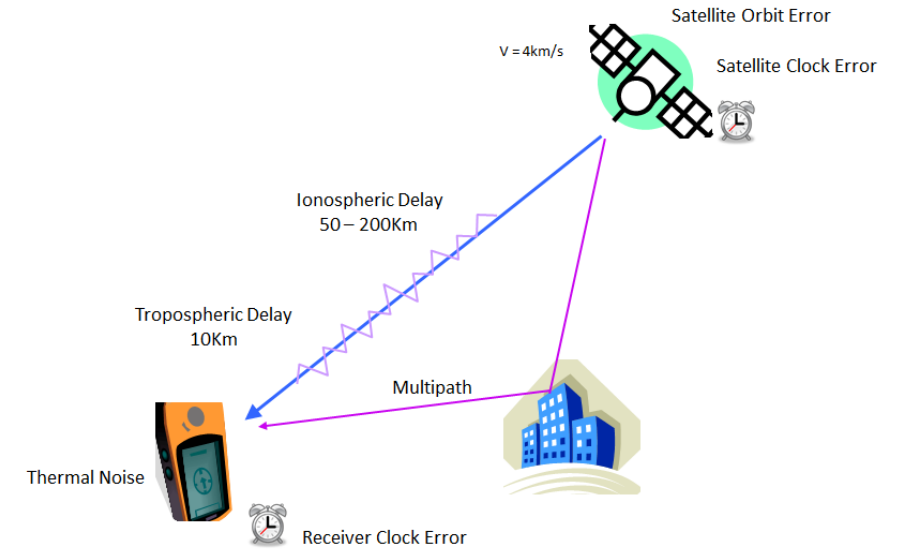
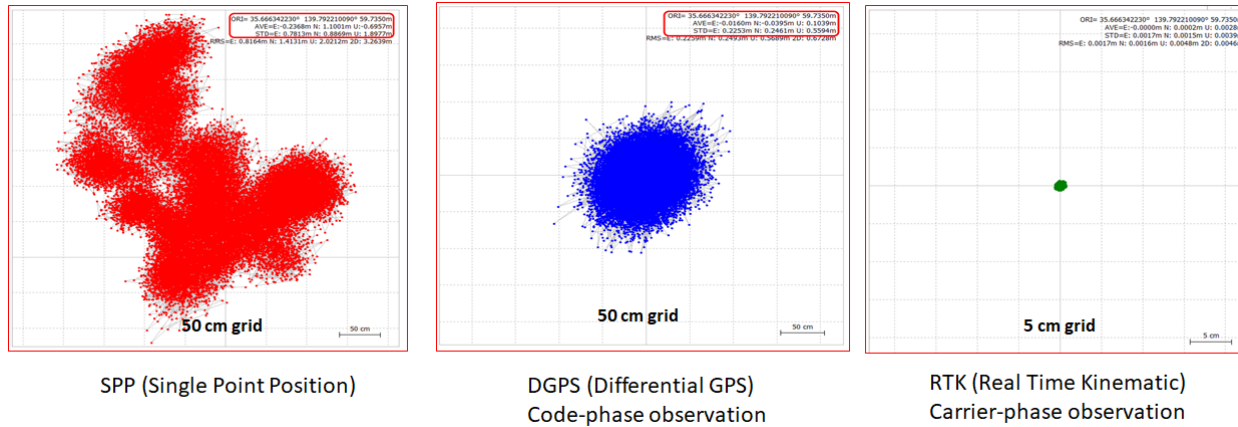

## GNSS Position Accuracy:

- Red: Single Point Position
- Blue: DGPS, Code-Phase Observation
- Green: RTK, Carrier Phase Observation

## GNSS Errors:

- Satellite Orbit Error
- Satellite Clock Error
- Ionospheric Delay
- Tropospheric Delay
- Receiver Clock Error
- Thermal Noise
- Multipath

# Data Observation Methods for High-Accuracy

Data Observation Method for DGPS / RTK / PPK

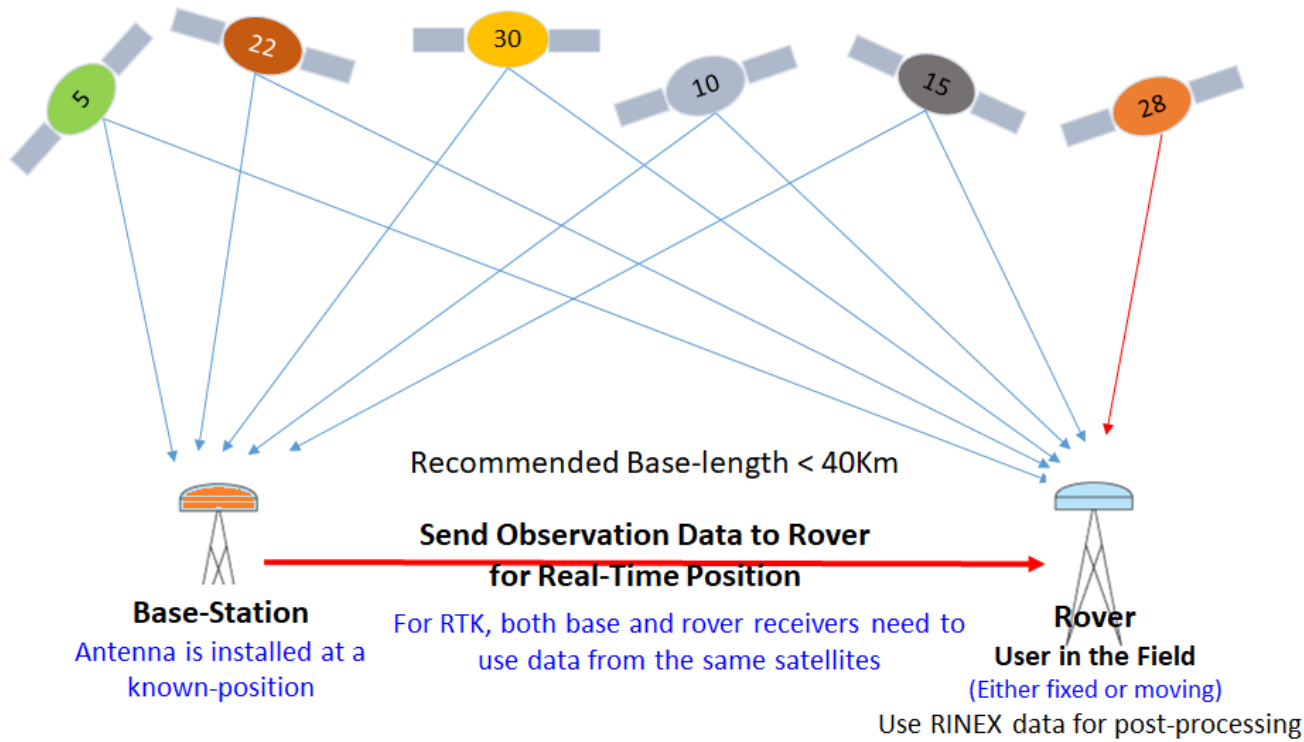

Data Observation Method for MADOCA PPP

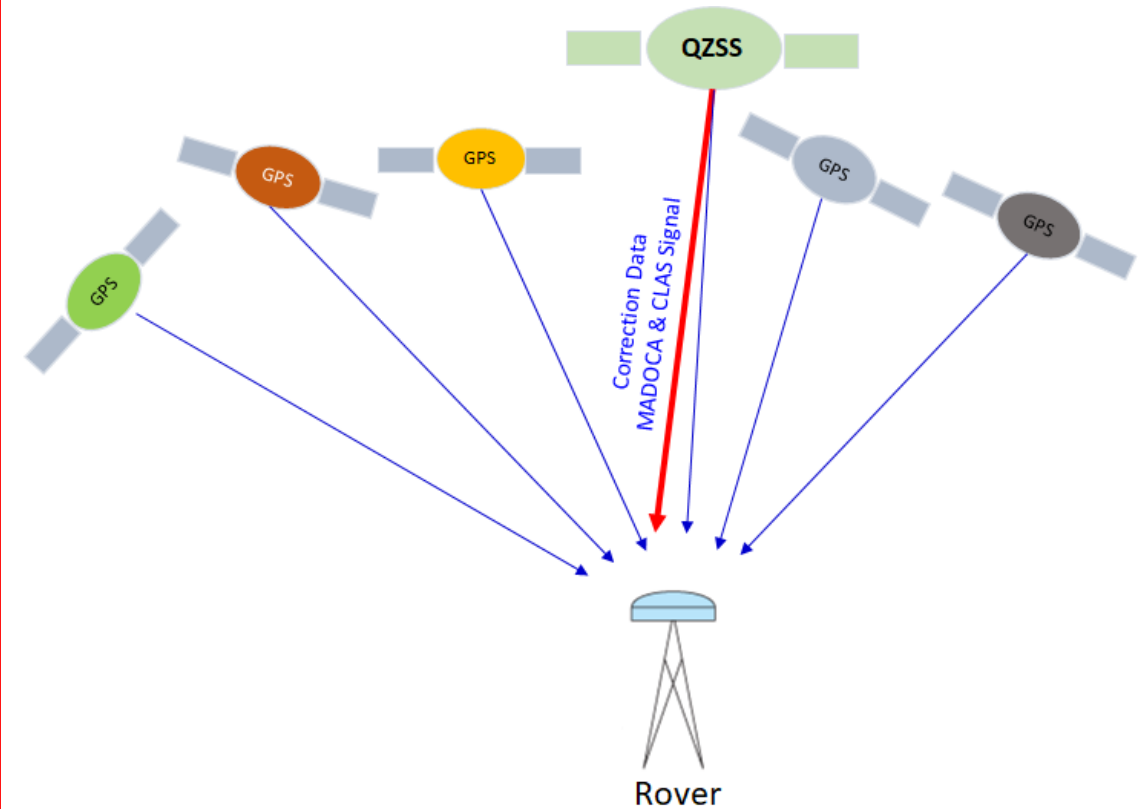

## MAD-WIN Setup

# MAD-WIN Setup

- Connect Antenna to the GNSS/MADDOCA receiver using the provided antenna cable
- Connect the receiver to a windows PC using a “micro-USB to USB” cable

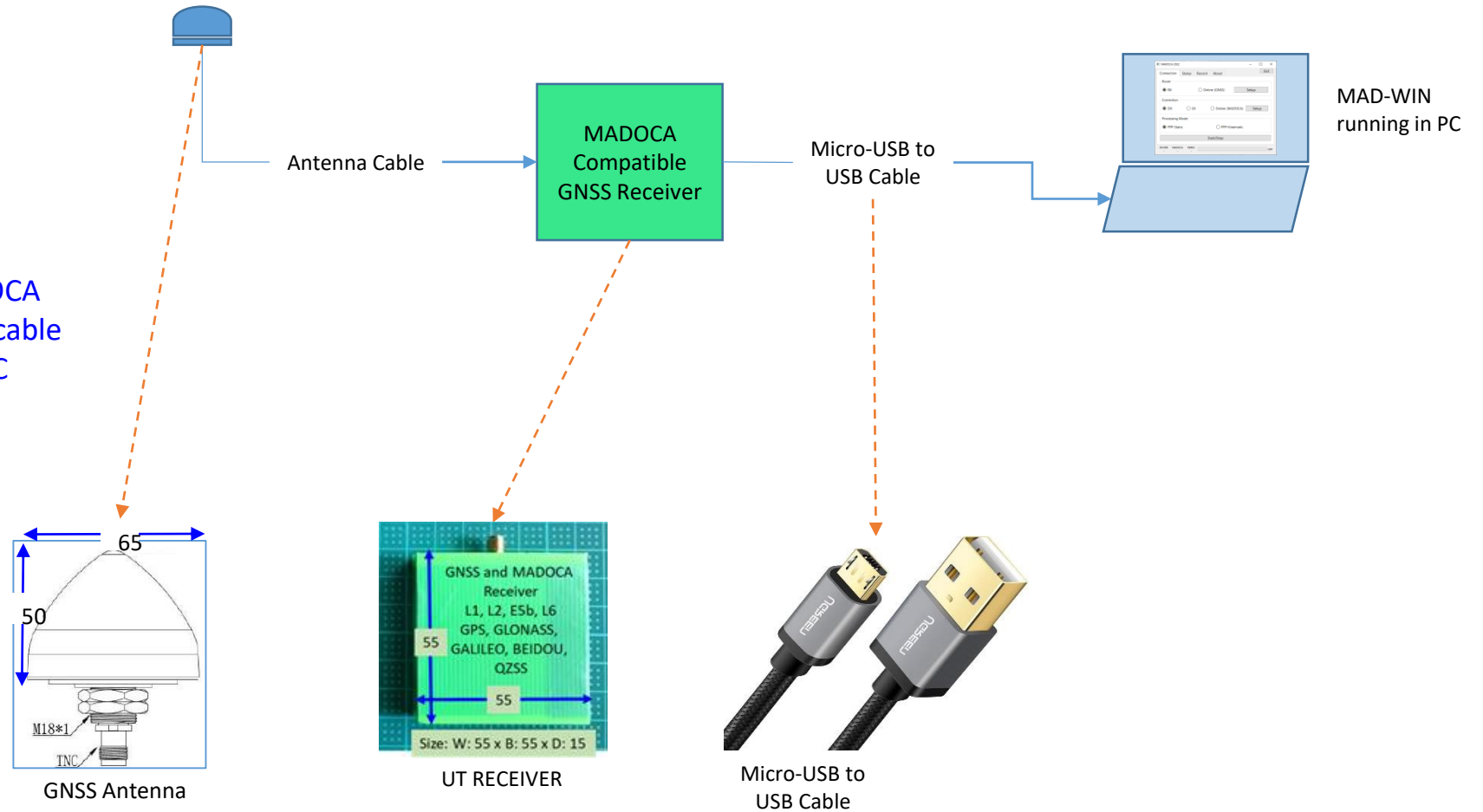

# Install and Run MAD-WIN

- Download MAD-WIN software from UT
- Unzip the software to a folder
- Run “Madoca\_win.exe” by double click from the MAD-WIN folder
- For easy access, create a Shortcut such as “Madoca\_Win - Shortcut”
- Copy this “Madoca\_Win - Shortcut” to desktop for easy access.
- Double click the Shortcut to run the application.

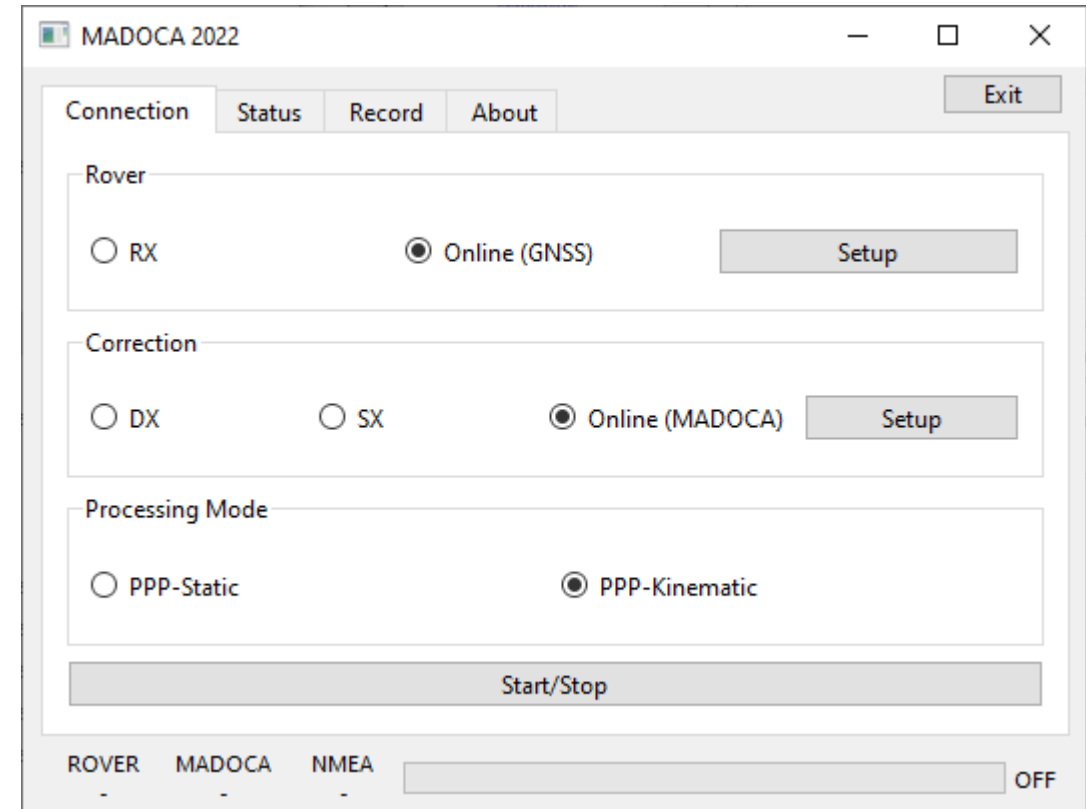

## MAD-WIN Setup: Case A

Both GNSS and MADOCA Receivers are connected to your PC

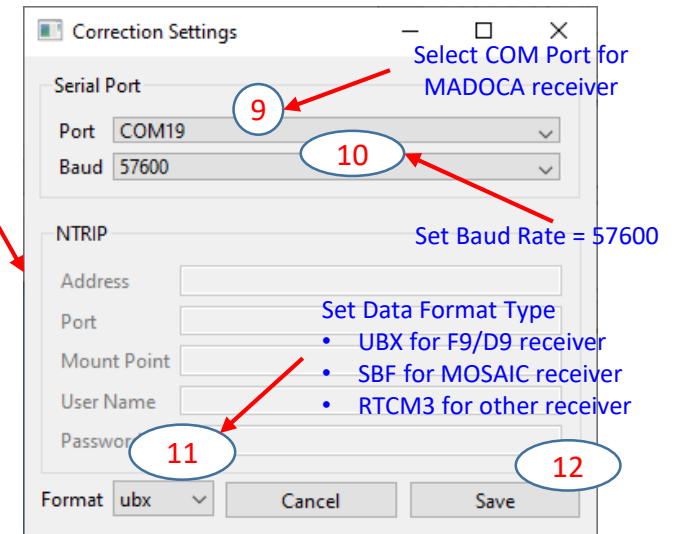
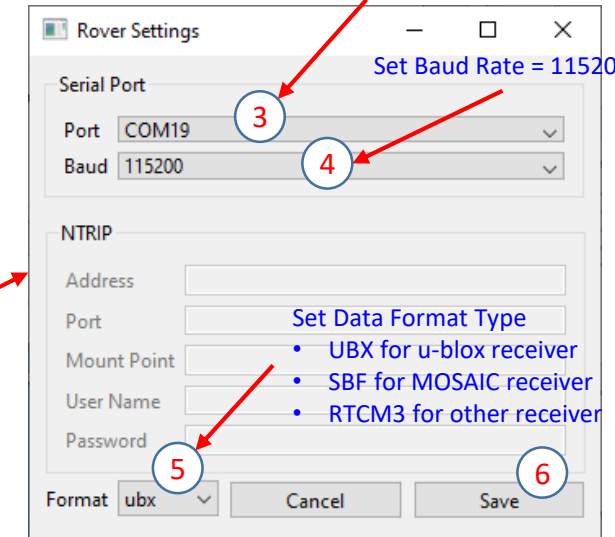
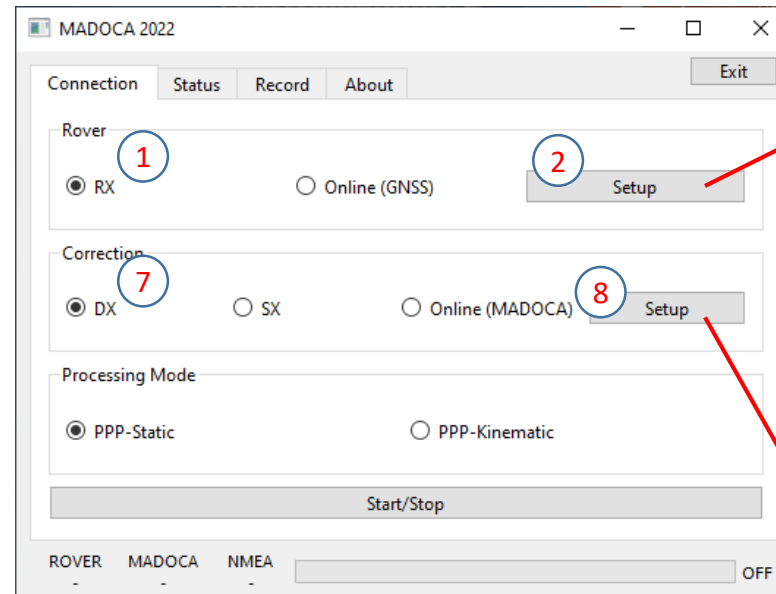
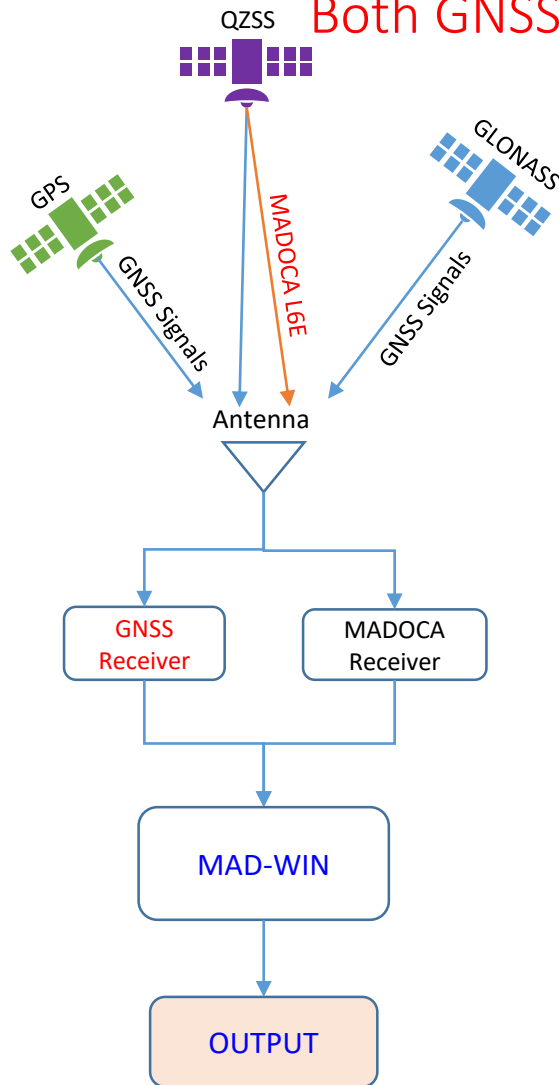



# MAD-WIN Setup: Case B

Only GNSS Receiver is connected to your PC

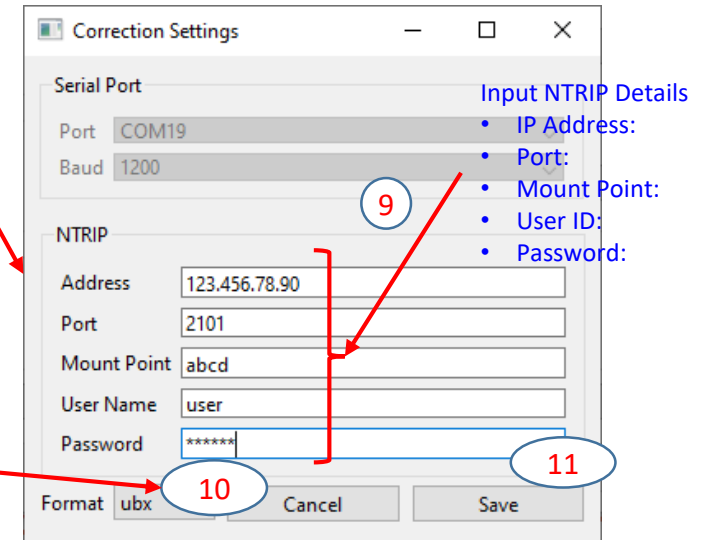
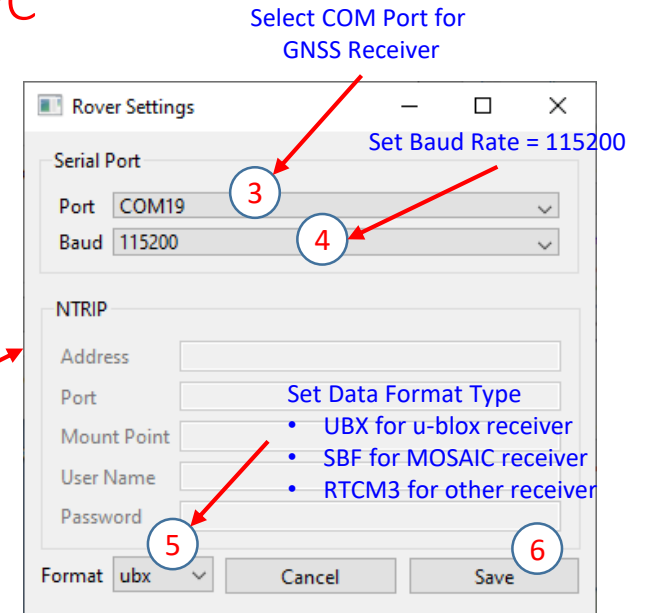
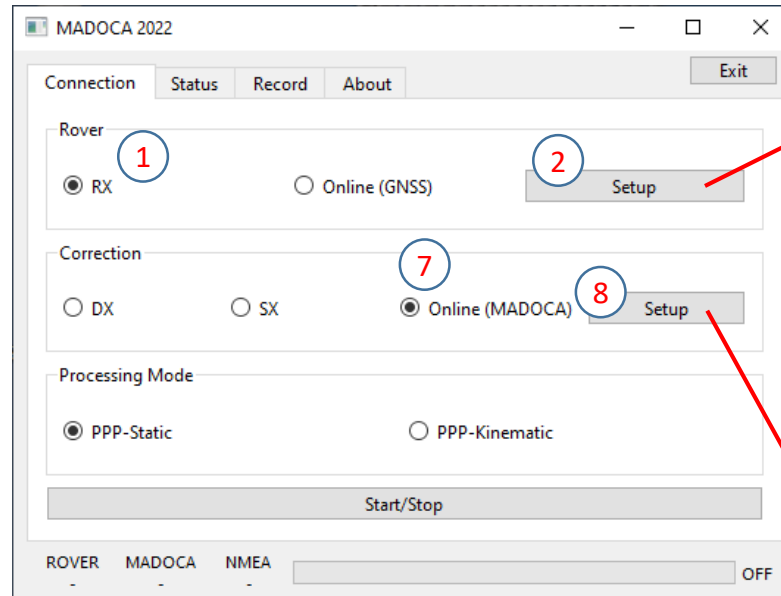
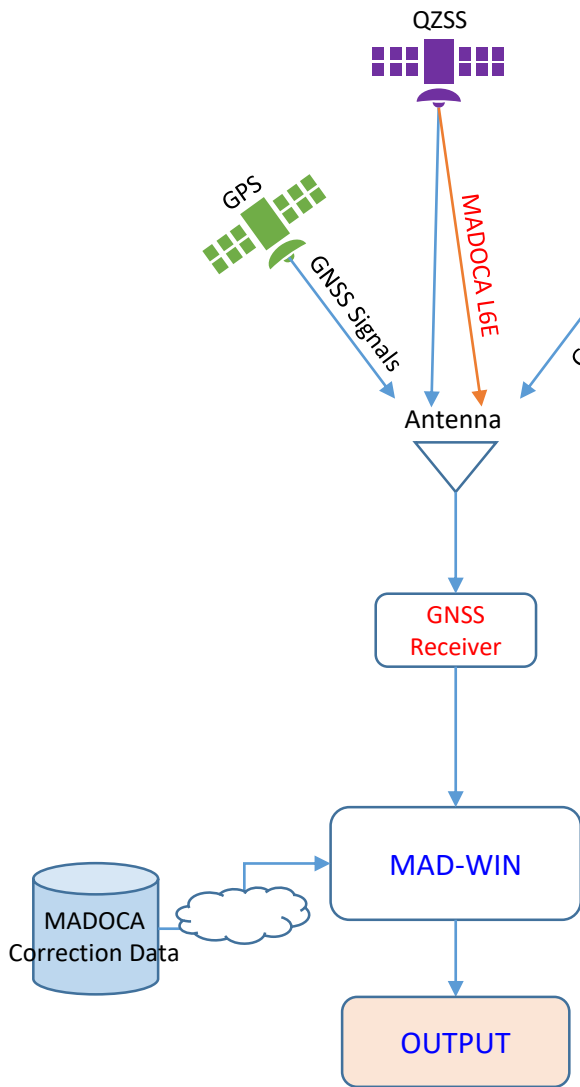

- Set Data Format Type
- UBX for D9C Receiver
  - SBF for MOSAIC Receiver
  - RTCM3 for Other

## MAD-WIN Setup: Case C

Both GNSS and MADOCA Receivers are located at a remote place

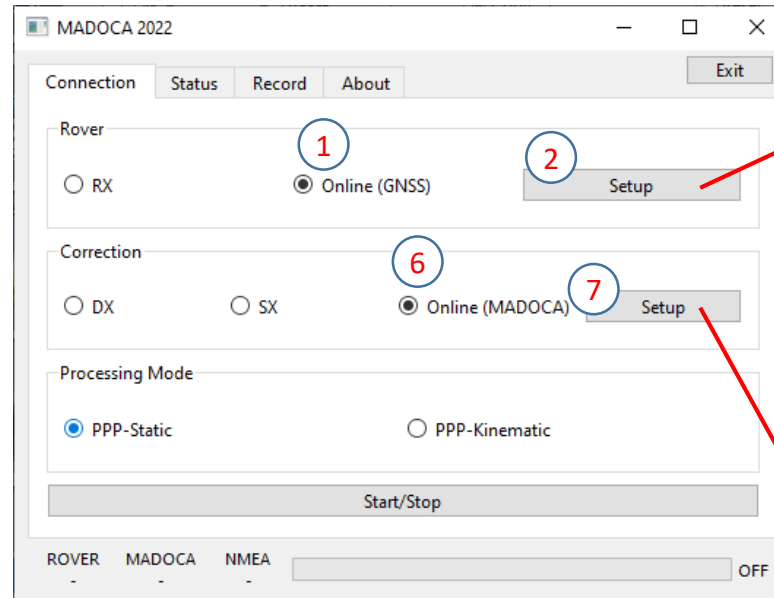
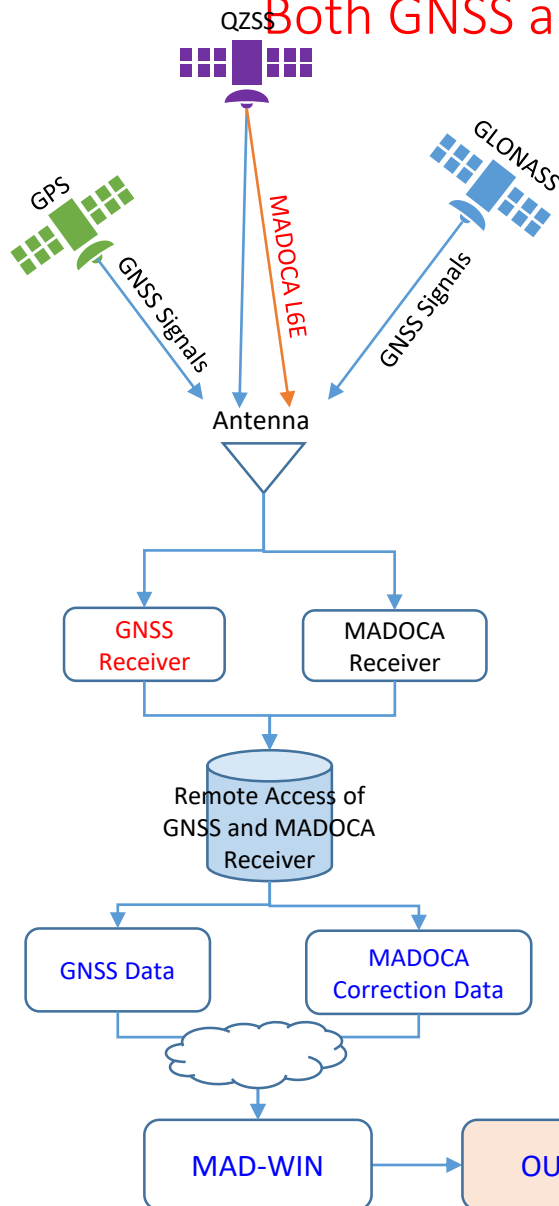

- Set Data Format Type
- UBX for D9C Receiver
  - SBF for MOSAIC Receiver
  - RTCM3 for Other

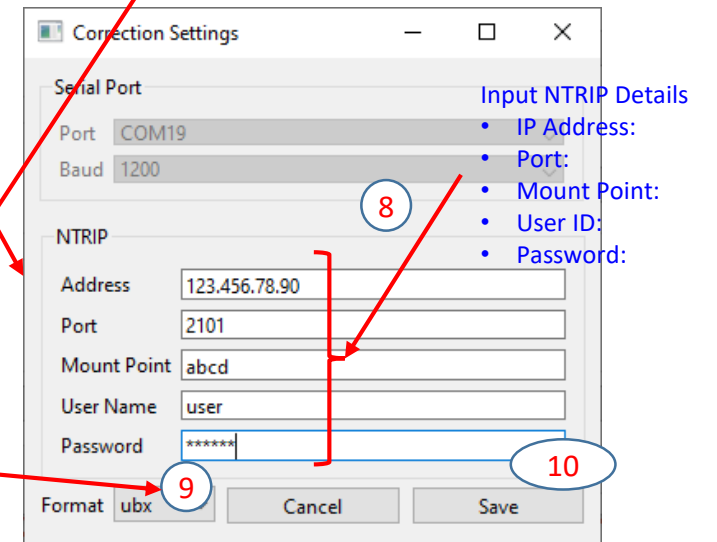
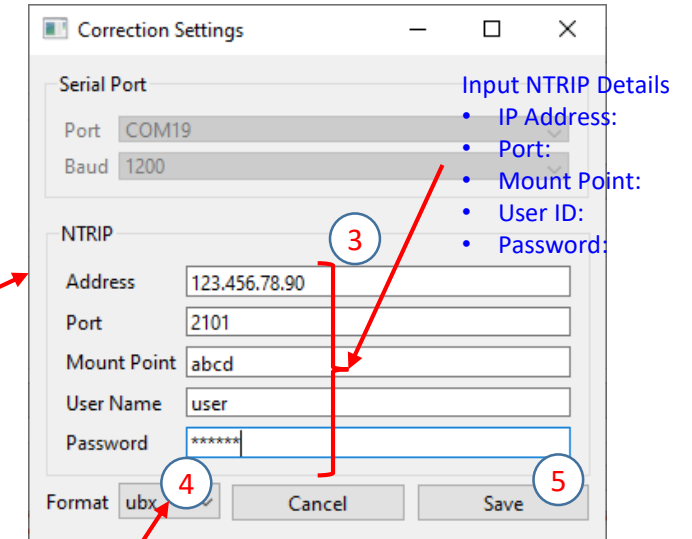

# MAD-WIN Setup: All Cases

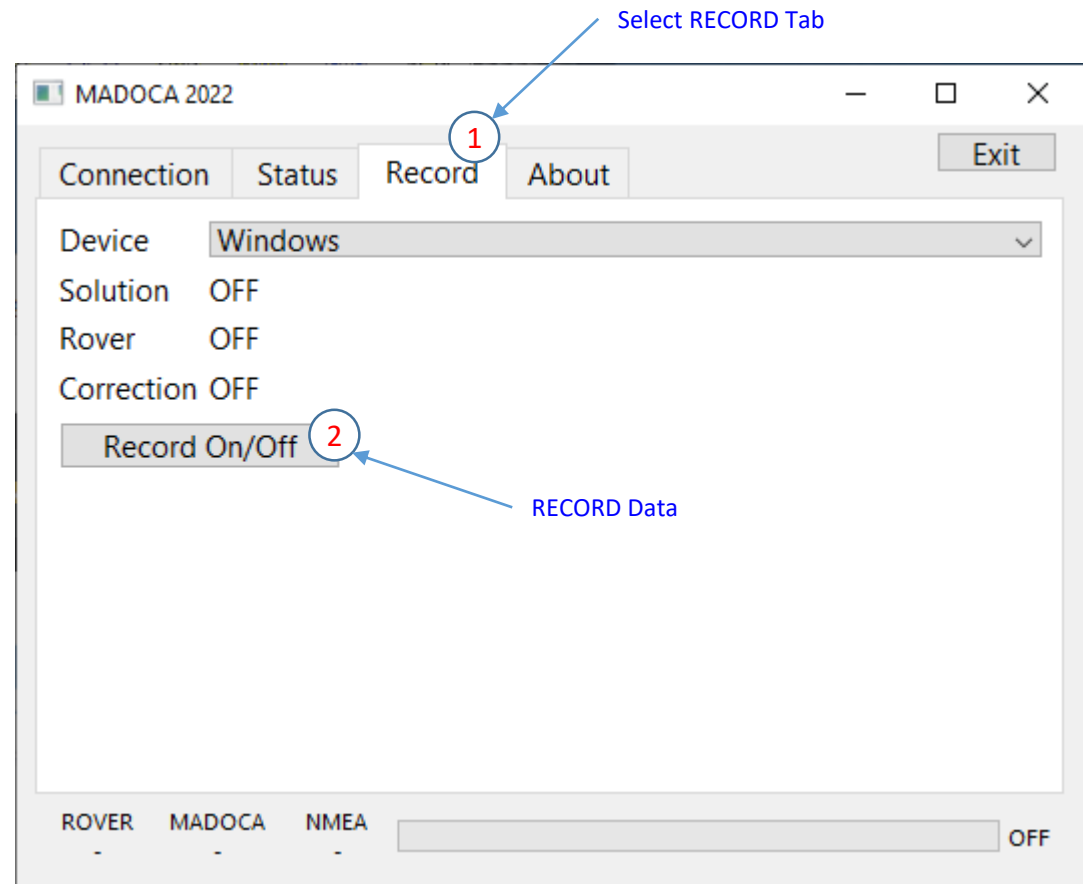
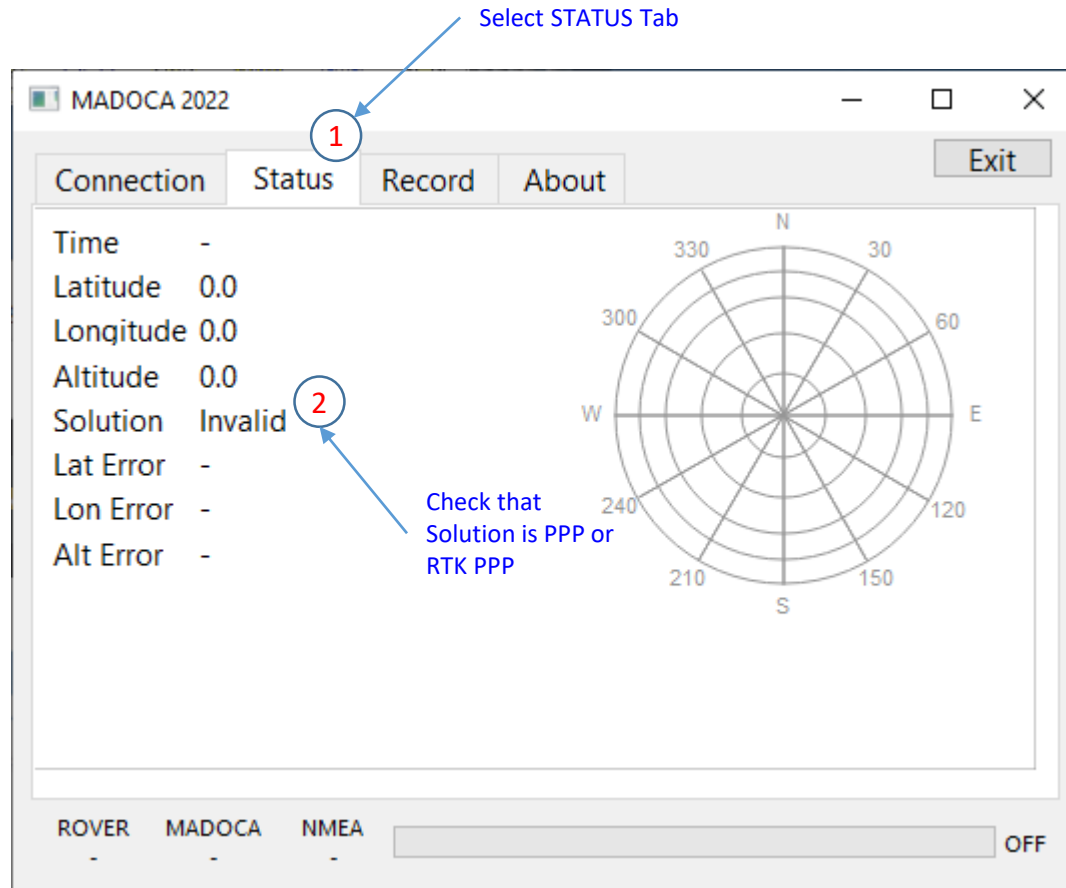

## MADROID Setup

# MADROID Setup: Receiver and Android Device

- Connect Antenna to the GNSS/MADOCA receiver using the provided antenna cable.
- Connect the receiver to an Android device using a “micro-USB to USB” cable and an OTG cable.
- OTG (On-The-Go) cable may be either Type-C or Micro-USB Type depending upon android device’s connection port.

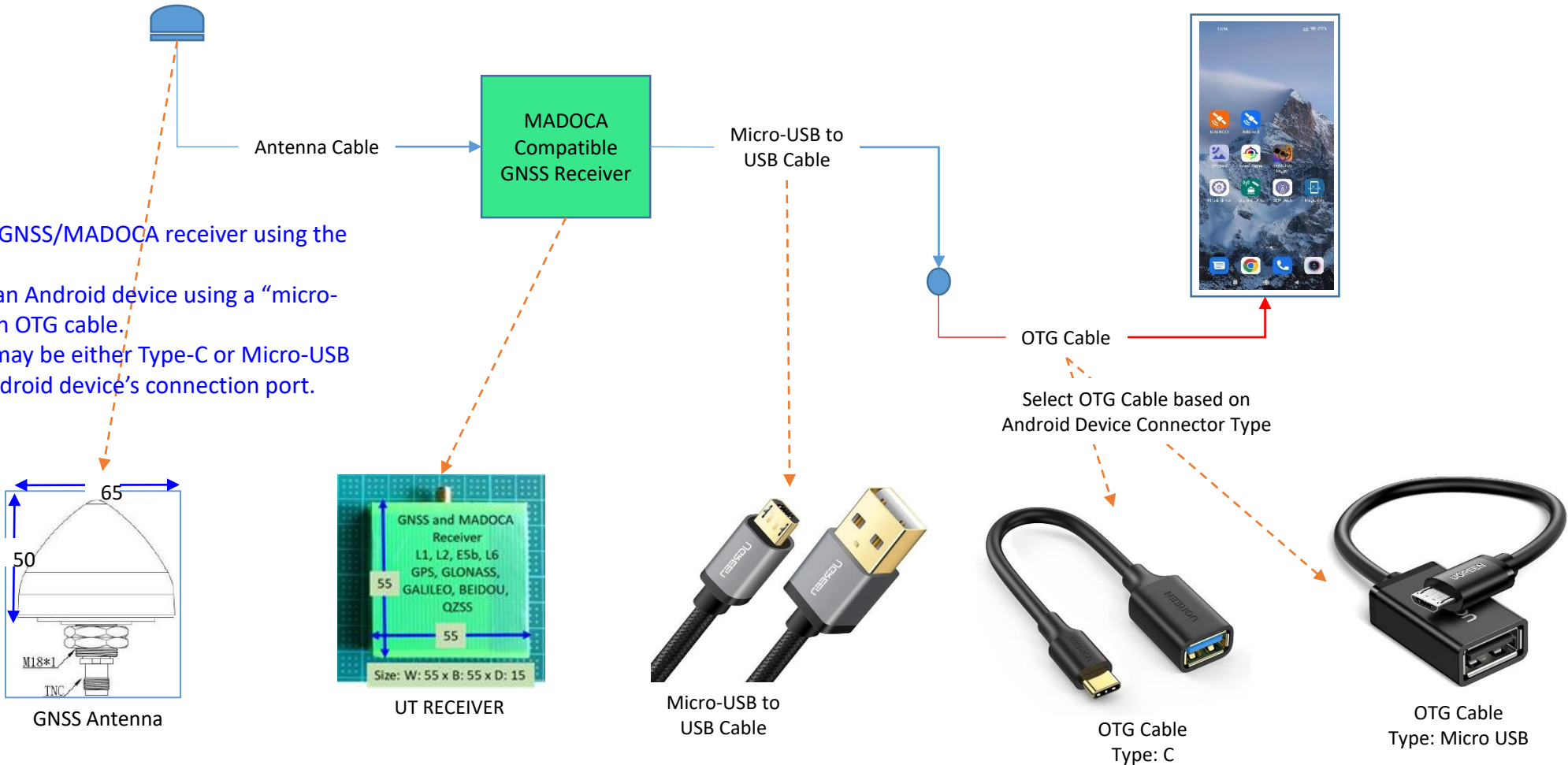

# Install MADROID APP

## Install MADROID APK in Android Device

- Get MADROID APK file from UT
- Connect Android device to the PC using an USB cable
- Set the device in Data Transfer mode
- Access Android device from PC
- Go to DOWNLOAD folder of Android device
- Copy MADROID file from PC to DOWNLOAD folder of Android device
- In the Android device, Go to File Manage APP
- Go to Download Folder. MADROID.apk file will be available here
- Tap the file, it will prompt for INSTALL access
- Say Yes and Install the APP
- After installation is done, go to device screens
- You will find the MADROID APP as shown here
- Run the APP and follow the instructions as shown in the next slide.
- Make sure that you have already connected Antenna, receiver etc. to the Android device before running the APP
- If ONLINE correction data will be used, make sure either WiFi or DATA is ON to access the NTRIP server via internet.

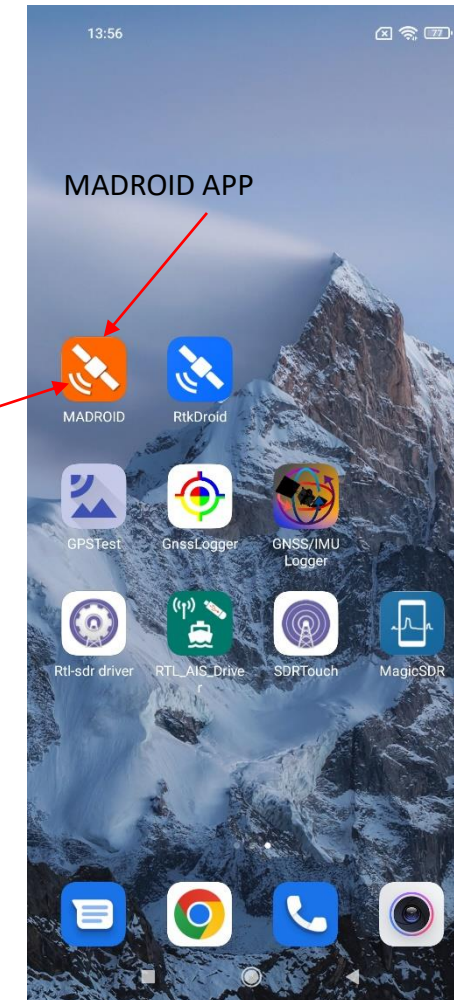

# MADROID GUI: Use this setting for system test

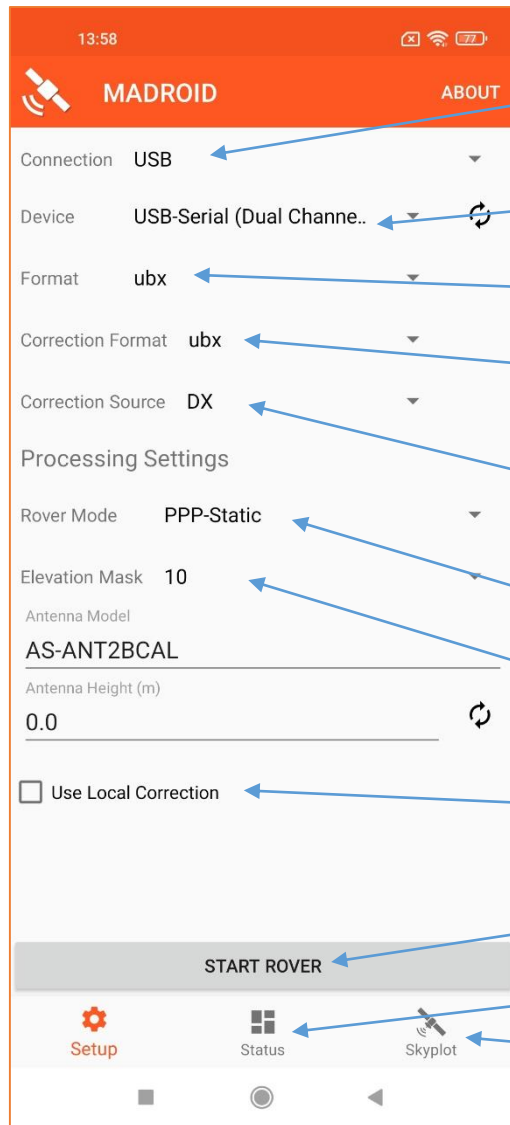

## CONNECTION

Select USB  
(Options are 1. USB 2. Bluetooth)

## DEVICE

In the Device the following must be visible if UT Receiver is connected:

- USB-Serial (Dual Channel) (Port 0)
- USB-Serial (Dual Channel) (Port 1)

## FORMAT

Select UBX to use GNSS Signals from UT Receiver connected to Android Device

## CORRECTION FORMAT

Select UBX if MADOCA Correction data from UT receiver to be used

Select other format such as RTCM or BINEX if correction data are provided in RTCM or BINEX format

## CORRECTION SOURCE

Select DX if correction data from the receiver connected to the Android device to be used

Select ONLINE if correction data from an ONLINE NTRIP server to be used

When ONLINE is selected, It is necessary provide NTRIP related information such as IP Address, Port, Mount Point, User ID and Password.

## ROVER MODE

Select ROVER MODE either PPP STATIC or PPP KINEMATIC

## ELEVATION MASK

Se ELEVATION MASK angle. Normally a mask angle of 10 - 15 degree is set.

## LOCAL CORRECTION

Do not select Local Correction unless you are provided Local Correction NTRIP information.

## START ROVER

Once all the settings are completed, Select START ROVER. This will begin MADOCA PPP Observation.

## STATUS

It shows current MADOCA PPP Status such as Position Data, Position Error etc.

## SKYPLOT

SKYPLOT shows all visible satellites, C/No values and Position Data.



# MADROID System Test Screen Shots

MADDOCA PPP Receiver System based on Android

The image displays three screenshots of the MADROID application interface on an Android device. The interface is divided into three main sections: Settings, Real-time Status, and Recording Controls.

**Left Screenshot (Settings):** Shows the configuration for the receiver. The connection is set to USB, and the device is USB-Serial (Dual Channel). The format is set to ubx, and the correction format is also ubx. The correction source is DX. The rover mode is PPP-Static, and the elevation mask is 10. The antenna model is AS-ANT2BCAL, and the antenna height is 0.0 meters. There is an option to use local correction, which is currently unchecked. A 'START ROVER' button is visible at the bottom.

**Middle Screenshot (Real-time Status):** Displays the current status of the receiver. The UTC time is 05:27:17. The coordinates are Latitude: 35.90202657° N and Longitude: 139.93857286° E. The ellipsoidal height is 59.349m, and the orthometric height is 21.385m. The speed is 0.15 km/hr, and the fix type is PPP. There are 13 satellites in view and 13 satellites in use. The PDOP is 3.4, HDOP is 1.8, and VDOP is 3.0. A skyplot is shown, displaying the positions of the satellites in the sky. Below the skyplot is a bar chart showing the signal strength of the satellites.

**Right Screenshot (Recording Controls):** Shows the recording status. The date is Dec 25, 2019, and the time is 05:34:17. The coordinates are Latitude: 35.90202310° and Longitude: 139.93857932°. The X and Y coordinates are 54N 404216.762m E and 54N 3973601.765m N, respectively. The ellipsoidal height is 59.848m, and the orthometric height is 21.884m. The fix type is PPP, and the speed is 0.11 km/hr. The HDOP is 1.9, VDOP is 3.0, and PDOP is 3.5. There are 13 satellites in view and 13 satellites in use. The latitude error is 0.191m, the longitude error is 0.171m, and the altitude error is 0.104m. The recording files are NMEA: 2019\_12\_25\_14\_28\_19.txt(201KB) and UBX: 2019\_12\_25\_14\_28\_19.ubx(1MB). A 'STOP RECORDING' button is visible at the bottom.



# MADROID PPP with Local Correction Setup

The image displays five sequential screenshots of the MADROID mobile application interface, illustrating the setup process for PPP with local correction.

- Screenshot 1: Connection Settings**
  - Connection: USB
  - Device: u-blox GNSS receiver
  - Format: ubx
  - Processing Settings:
    - Rover Mode: PPP-Static
    - Elevation Mask: 10
    - Antenna Model: TWIVP6000
    - Antenna Height (m): 0.0
- Screenshot 2: NTRIP Settings**
  - NTRIP Settings:
    - Address: madoca.ntrip-mgm.net
    - Port: 2101
    - Mount Point: MDC0
    - User Name: dinesh@csis.u-tokyo.ac.jp
    - Password: \*\*\*\*\*
  - Local Correction Settings:
    - Use Local Correction
    - Address: [Empty]
    - Port: 80
    - Mount Point: [Empty]
- Screenshot 3: Local Correction Settings**
  - Local Correction Settings:
    - Use Local Correction
    - Address: [Empty]
    - Port: 80
    - Mount Point: [Empty]
- Screenshot 4: Skyplot**
  - UTC Time: 07:16:19
  - Latitude: 35.68971662° N
  - Longitude: 139.75281501° E
  - Ellipsoidal Height: 56.785m
  - Orthometric Height: 18.995m
  - Speed: 0.15 km/hr
  - Fix type: Fix RTK
  - Satellites in view: 15
  - Satellites in use: 15
  - PDOP: 1.9
  - HDOP: 1.1
  - VDOP: 1.6
  - Visual representation of satellite positions in the sky.
- Screenshot 5: Status**
  - Date: Sep 15, 2020
  - Time: 07:16:23
  - Latitude: 35.68971663°
  - Longitude: 139.75281501°
  - X: 54N 387152.640m E
  - Y: 54N 3950250.977m N
  - Ellipsoidal Height: 56.780m
  - Orthometric Height: 18.990m
  - Fix Type: Fix RTK
  - Speed: 0.09 km/hr
  - HDOP: 1.1
  - VDOP: 1.6
  - PDOP: 1.9
  - Satellites in View: 15
  - Satellites in Use: 15
  - Latitude Error: 0.065m
  - Longitude Error: 0.055m
  - Altitude Error: 0.028m
  - NMEA: 2020\_09\_15\_16\_08\_35.txt(279KB)
  - RAW: 2020\_09\_15\_16\_08\_35.ubx(2MB)