

4 February 2011

English only

**Committee on the Peaceful
Uses of Outer Space
Scientific and Technical Subcommittee
Forty-eighth session
Vienna, 7-18 February 2011
Item 10 of the provisional agenda*
Use of nuclear power sources in outer space**

“Safety in the Design and Development of United States Space NPS Applications”¹

By Reed Wilcox, Jet Propulsion Laboratory, California Institute of Technology²

Abstract

The United States of America subjects its planned space nuclear power source (NPS) applications to an extensive safety design and development process that encompasses all of the relevant guidance recommended in the Safety Framework for Nuclear Power Source Applications in Outer Space (Ref. 1) as jointly published by the United Nations Committee on the Peaceful Uses of Outer Space Scientific and Technical Subcommittee and the International Atomic Energy Agency in 2009. Safety considerations receive close attention from the earliest design stages of both space NPSs and their proposed mission applications. Since the design/development phase for space NPSs typically occurs well in advance of specific NPS applications, the safety basis for U.S. NPSs initially focuses on containing NPS fuel under a wide range of postulated accident scenarios. Subsequent proposed mission applications focus on detailed risk assessments of the integrated NPS application (i.e. NPS, spacecraft, launch system, mission design, flight rules) to identify potential design modifications that can enhance the mission’s nuclear safety consistent with accomplishing mission objectives. Quantitative requirements on the performance of safety systems guide design/development, but are not as important as a rigorous launch nuclear safety review process that encourages continual evaluation and consideration of safety enhancements throughout the entire design, development and approval process.

* A/AC.105/C.1/L.306.

¹ This paper is also available without images, edited and in all official languages of the United Nations, in document A/AC.105/C.1/L.313.

² © 2010 California Institute of Technology. Government sponsorship acknowledged. This research was carried out at the Jet Propulsion Laboratory, California Institute of Technology, under a contract with the National Aeronautics and Space Administration.



Introduction

The United States of America (USA) has a long history of using space NPS safely. Since 1961, the USA has had twenty-nine launches involving space radioisotope power system (RPS) applications³ and one launch of a space reactor. Initial RPS applications involved communications, meteorological and navigational applications. However as illustrated in Figure 1, the vast majority of RPS applications over the last 30 years have involved science applications conducted under the auspices of the National Aeronautics and Space Administration (NASA) in partnership with the United States Department of Energy (DOE). All of NASA’s RPS missions were enabled by the RPSs and include: the Apollo missions to the Moon; the Pioneer 10 mission to Jupiter; the Pioneer 11 missions to Jupiter, Saturn and beyond; the Viking and Pathfinder missions to the surface of Mars; the Voyager 1 mission to Jupiter, Saturn and beyond; the Voyager 2 mission to Jupiter, Saturn, Uranus, Neptune and beyond; the Galileo mission that orbited Jupiter for 8 years; the Ulysses mission that operated in heliocentric orbit for nearly 20 years; the Cassini mission that continues to operate in orbit around Saturn; and the New Horizons mission in flight to Pluto.

Over this nearly 50 year history, three accidents involving USA RPSs have occurred, none of which were caused by a failure of the RPS, and all of which whose safety features performed as designed : the mission abort of the TRANSIT 5BN-3 navigational satellite in 1964 that resulted in the high-altitude burn-up on reentry of the mission’s RPS; the launch abort of the NIMBUS-B-1 meteorological satellite in 1968 that resulted in the RPS falling in the Pacific where its heat source was recovered; and the Apollo 13 lunar mission that was successfully targeted to the Tonga Trench in the Pacific Ocean after the mission was aborted.

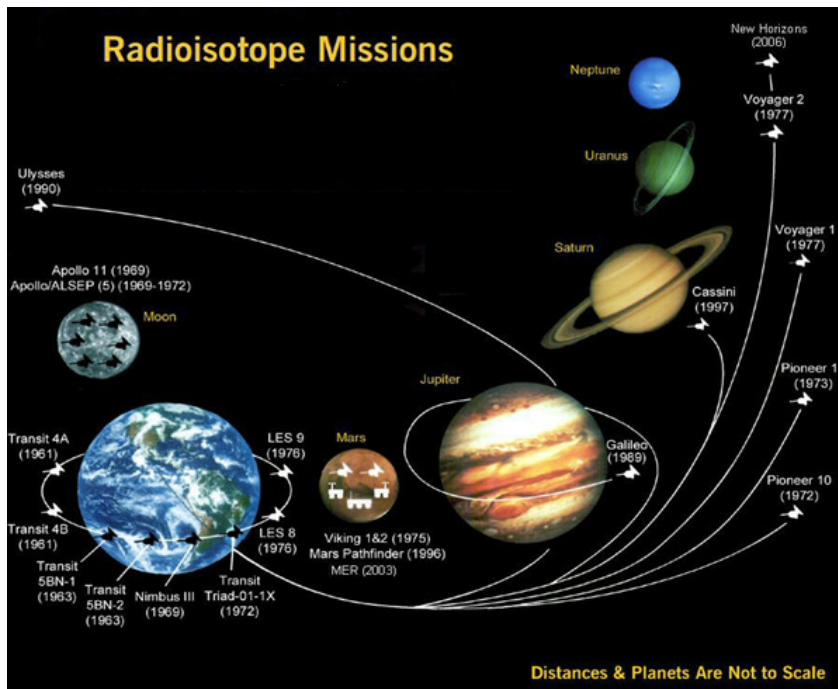

Figure 1: United States RPS Mission Applications

³ Including the Mars Pathfinder mission that used light-weight radioisotope heater units

Comparison of United Nations/International Atomic Energy Agency Safety Framework with NASA’s and DOE’s Nuclear Safety Implementation for Space RPS Applications

Over the decades, NASA, working in concert with DOE, has developed a comprehensive safety framework for both designing and developing RPSs and their space applications. This framework integrates safety considerations into every aspect and phase of both the RPS design and development process and into the RPS application design, development and implementation process.

The USA safety framework closely parallels the Safety Framework for Nuclear Power Source Applications in Outer Space (hereafter referred to as the UN/IAEA Safety Framework) as jointly published by the United Nations Committee on the Peaceful Uses of Outer Space Scientific and Technical Subcommittee and the International Atomic Energy Agency in 2009 (Ref.1). As summarized in Figure 2, United States federal law aligns with the three major categories of guidance contained in the UN/IAEA Safety Framework: governmental, management and technical. The USA development and implementation of its own safety framework has been requirement-based; in other words, the USA process requires specific actions and processes that if not followed would preclude the launching of an RPS application.

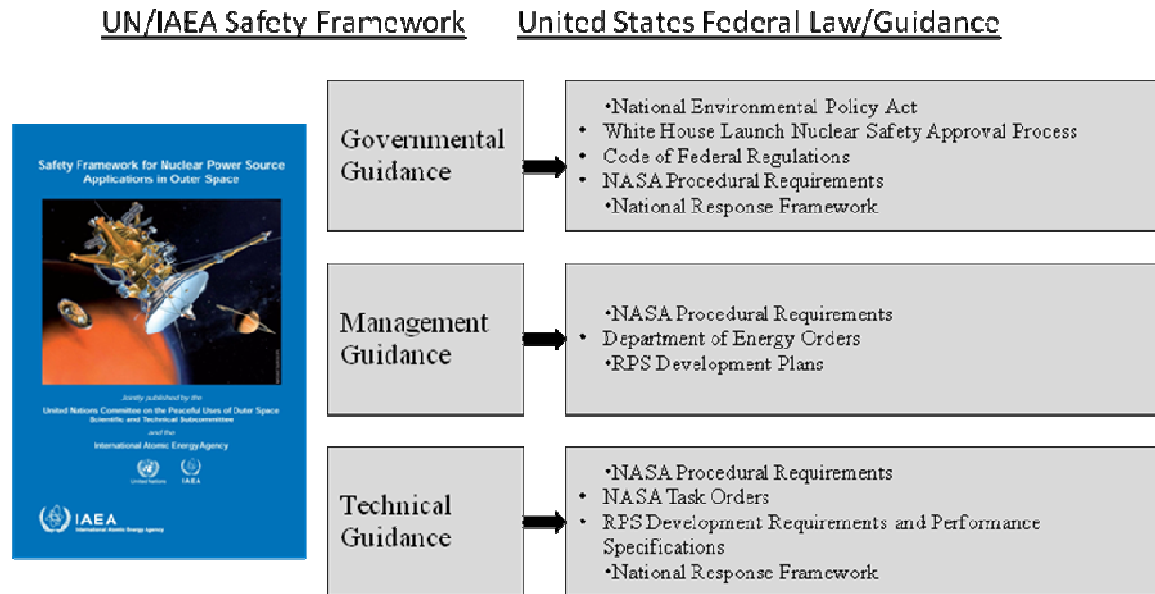

Figure 2: Comparison of UN/IAEA Safety Framework with NASA’s Nuclear Safety Implementation for Space NPS Applications

- USA Governmental Guidance

USA governmental guidance has been codified into federal laws, Presidential directives, agency requirements and multi-agency plans. The National Environmental Policy Act (NEPA) and the Presidential Launch Nuclear Safety

Approval Process are the established processes for justifying⁴ and authorizing⁵, respectively, USA RPS applications. (NEPA requires NASA to complete an environmental impact statement (EIS) early in a mission's design and development phase. The EIS must assess the potential environmental impacts of the baseline design for the mission and reasonable design alternatives for accomplishing the mission's objectives. The Presidential Launch Nuclear Safety Approval Process requires a detailed safety analysis of the actual system (i.e. power source, spacecraft, launch vehicle and mission design) built for launch. Additional safety policies and requirements⁶ have been formalized by NASA in the United States Code of Federal Regulations and NASA Procedural Requirements to further define the expectations and procedures required of government officials, programs and projects in initiating, conducting and participating in the development of RPSs and RPS applications. The USA has also developed a comprehensive National Response Framework (Ref. 2) for preparing⁷ and responding to disasters and emergencies, including specifically accidents involving space NPS applications.

- USA Guidance for Management

USA management guidance has been documented in agency requirements and RPS development plans. NASA Headquarters has the primary responsibility for the safety of a space RPS application.⁸ The NASA Headquarters division directorate responsible for the mission designates a program executive for each mission to ensure that the agency implements the mission according to approved processes. In this capacity, the program executive for an RPS mission application has the responsibility for meeting the requirements of the NEPA, the Presidential Launch Nuclear Safety Approval Process and the National Response Framework. Consistent with the UN/IAEA Safety Framework, the program executive interfaces directly with each of the organizations developing and implementing a mission involving an RPS application. NASA Headquarters formalizes arrangements with each of the participants that have a substantive responsibility involving nuclear safety. The management responsibility for nuclear safety is integrated into the overall management structure of the mission with regular reporting and accountability reviews involving all relevant participants.⁹ (These participants include NASA Headquarters, DOE, NASA Centers and their respective support contractors.)

- USA Technical Guidance

USA technical guidance, similar to management guidance, has been documented in agency requirements and RPS development plans. The technical guidance, as described in greater detail in the following section, provides requirements that have been satisfied by developing, maintaining and applying multi-agency expertise in the definition, testing and analysis of launch and mission accidents/anomalies involving RPSs.¹⁰ NASA and DOE RPS application safety requirements cover all phases of a mission and apply to both the development phase of an RPS and its intended mission application.¹¹ NASA and DOE working together under the auspices of a formal interagency agreement, prepare comprehensive risk assessments that support both the design and development process and the launch authorization process.¹² Further these risk assessments support the development of detailed multi-agency radiological contingency plans that strive to mitigate the potential consequences of an accident involving a space RPS application.¹³

⁴ Section 3.2 of the UN/IAEA Safety Framework covers "Justification for space nuclear power source applications" (Ref. 1)

⁵ Section 3.3 of the UN/IAEA Safety Framework covers "Mission launch authorization" (Ref. 1)

⁶ Section 3.1 of the UN/IAEA Safety Framework covers "Safety policies, requirements and processes" (Ref. 1)

⁷ Section 3.4 of the UN/IAEA Safety Framework covers "Emergency preparedness and response" (Ref. 1)

⁸ Section 4.1 of the UN/IAEA Safety Framework covers "Responsibility for Safety" (Ref. 1)

⁹ Section 4.2 of the UN/IAEA Safety Framework covers "Leadership and management for safety" (Ref. 1)

¹⁰ Section 5.1 of the UN/IAEA Safety Framework covers "Technical competence in nuclear safety" (Ref. 1)

¹¹ Section 5.2 of the UN/IAEA Safety Framework covers "Safety in design and development" (Ref. 1)

¹² Section 5.3 of the UN/IAEA Safety Framework covers "Risk assessments" (Ref. 1)

¹³ Section 5.4 of the UN/IAEA Safety Framework covers "Accident consequence mitigation" (Ref. 1)

Nuclear Safety Design and Development Requirements for USA Space RPS Mission Applications

DOE and NASA maintain a comprehensive framework of nuclear safety requirements that govern the full range of design, development and implementation phases of an RPS mission application. The compliance with this framework is achieved by the application of both public and internal government deliberative processes that, as summarized above, have been codified into federally-mandated laws, processes and requirements.

NASA procedural requirements provide five guiding requirements that influence the definition, design, development and implementation of an RPS application:

- *“Basic designs of vehicles, spacecraft, and systems utilizing radioactive materials provide protection to the public, the environment, and users such that radiation risk resulting from exposures to radioactive sources are as low as reasonably achievable”* (Ref. 3, Section 6.2.2.b.);
- *Nuclear safety considerations are incorporated from the initial design stages throughout all project stages to ensure that overall mission radiological risk is acceptable* (Ref. 3, Section 6.2.2.c.);
- *All space flight equipment (including medical and other experimental devices) that contain or use radioactive materials are identified and analyzed for radiological risk* (Ref. 3, Section 6.2.2.d.);
- *Site-specific ground operations and radiological contingency plans are developed commensurate with the risk represented by the planned launch of nuclear materials* (Ref. 3, Section 6.2.2.e.); and
- *Radiological contingency planning includes provisions for emergency response and support for source recovery efforts* (Ref. 3, Section 6.2.2.f.).

The first requirement establishes the risk to human health and the Earth’s biosphere as the primary nuclear safety consideration in designing a mission and its spacecraft, launch vehicle and supporting elements. This requirement coincides directly with the UN/IAEA Safety Framework “Safety Objective”.¹⁴ The second requirement ensures that nuclear safety considerations encompass all phases of a mission, from the earliest conceptual design phases all the way through to the end-of-mission. The third requirement extends the application of the first two requirements to encompass more than just RPSs (including radioisotope heater units), but any element of the mission that involves radioactive material.¹⁵ The fourth and fifth requirements align with the requirements placed on NASA by the National Response Framework (Ref. 2).

These requirements, implemented in concert with satisfying the NASA Procedural Requirements for NEPA and the Presidential Launch Nuclear Safety Approval Process, have a major impact on a mission’s nuclear safety throughout its design/development process. For example, as indicated in the previous section, prior to finalizing the proposed RPS application’s design, NEPA requires NASA to prepare an EIS that objectively assesses and seeks public comment on the potential environmental impacts of a proposed RPS application and reasonable alternatives (e.g. a solar-powered spacecraft design) for accomplishing its objectives. In addition, since the NEPA EIS focuses on the consequences of potential launch/mission accidents, an early nuclear safety assessment of the proposed RPS application necessarily requires NASA to identify the specific accident scenarios (i.e. the sequence of launch or mission accident or anomalous events), including their probabilities, that lead to potential

¹⁴ “The fundamental safety objective is to protect people and the environment in Earth’s biosphere from potential hazards associated with relevant launch, operation and end-of-service phases of space nuclear power source applications.” (Ref. 1, “Safety objective”, Section 2, page 2)

¹⁵ In fact, NASA has established 5 levels of nuclear safety compliance depending on the amount of radioactive material involved in a mission. For all RPS missions to date, including those involving radioisotope heater units, the most stringent level of nuclear safety involving launch nuclear safety approval from the Executive Office of the President has been required.

environmental impacts (e.g. latent cancer health effects, land contamination, population risk). Because of the rigorous (i.e. quantitative) approach of these assessments, they facilitate the identification of spacecraft, launch vehicle, mission design and flight rule changes that could enhance nuclear safety and reduce the risk of potential accidents.

Similarly, the Presidential Launch Nuclear Safety Approval Process's requirement for a detailed safety analysis of the actual system (i.e. power source, spacecraft, launch vehicle, mission design) built for launch, results in a more highly-developed model of the RPS application. This model provides a tool that affords greater insight into the elements of the application that influence the application's nuclear risk and provides information that guides the development of site-specific radiological contingency plans. Moreover, since the Presidential Launch Nuclear Safety Approval Process involves all the federal government agencies that have a substantive safety responsibility for various aspects of the mission (i.e. NASA - spacecraft/mission safety; DOE - RPS safety; Department of Defense - launch site and range safety; and Environmental Protection Agency - accident cleanup safety), the development and evaluation of the safety analysis provides a focal point for coordinating inter-agency resolution of any nuclear safety issues identified during the development phase of the application.

Implementation of Nuclear Safety in Space RPS Applications

In satisfying the procedural requirements identified above, NASA and DOE implement 'nuclear safety' at every stage of development and with every element of an RPS application. Since the design and development of a new RPS typically takes five or more years, its development precedes that of an RPS application. As a result, DOE develops the nuclear safety aspects of its RPS designs based on a broad range of potential mission application designs and performance requirements, both of which can present competing design paths or challenges to some safety performance goals. To the extent that any RPS safety performance goal cannot be fully optimized for a specific RPS application, the mission application must then consider design options for achieving an acceptable level of safety. In other words, neither the RPS nor RPS application nuclear safety designs alone result in an application's radiation risk being 'as low as reasonably achievable'. Only through a continuous and integrated system level approach does the RPS application typically achieve an acceptable level of safety.

DOE's RPS development programs establish component and system level safety objectives, requirements and performance specifications. Because of the intermittent nature of NASA's RPS applications (i.e. one to two missions per decade), DOE continuously identifies, evaluates, develops and implements safety enhancements to its RPS systems relatively independent of NASA's specific mission plans. For major developments of new RPSs, DOE and NASA cooperate in establishing nuclear safety requirements that involve all aspects of an RPS. DOE further interprets these requirements into specific RPS system-level performance objectives that are verified by test and/or analysis. From the earliest design phases and throughout the development phase, the progress towards meeting these requirements and performance objectives are regularly tracked and reported on at design/development reviews involving DOE, NASA and their supporting participant organizations.

The development of the General Purpose Heat Source (GPHS) -- the building block of recent DOE RPSs -- provides an example of DOE's continuous and integrated system level approach to nuclear safety. The GPHS modules (see Figure 3) are designed to contain their plutonium dioxide fuel under a wide range of normal conditions and accident conditions such as launch pad explosions, solid and liquid propellant fires, shrapnel impacts, ground impact and reentry. Even though the GPHS has been in use for nearly 30 years, DOE has enhanced its safety features several times based on the results of both general and mission-specific safety tests and analyses. Information pertinent to GPHS design nuclear safety comes from both DOE RPS safety tests (see Figure 4) and from NASA accident environment definition tests (see Figure 5). These tests both support the definition and assessment of safety requirements and performance specifications, but also provide data for enhancing nuclear safety models that can be applied throughout the design/development process of future RPSs and RPS applications.

NASA’s implementation of nuclear safety spans all phases and all elements of an RPS application. In addition to the RPS’s nuclear safety design/development process discussed above, the design of an RPS application typically presents multiple opportunities for “*providing protection to the public, the environment, and users such that radiation risk resulting from exposures to radioactive sources are as low as reasonably achievable*” (Ref. 3, Section 6.2.2.b.). As indicated in Figure 6 and discussed above, initiating and conducting nuclear safety risk assessments throughout the design/development phase provides a capability for identifying and assessing the nuclear safety aspects of potential launch system, spacecraft and mission design options. For example, in certain

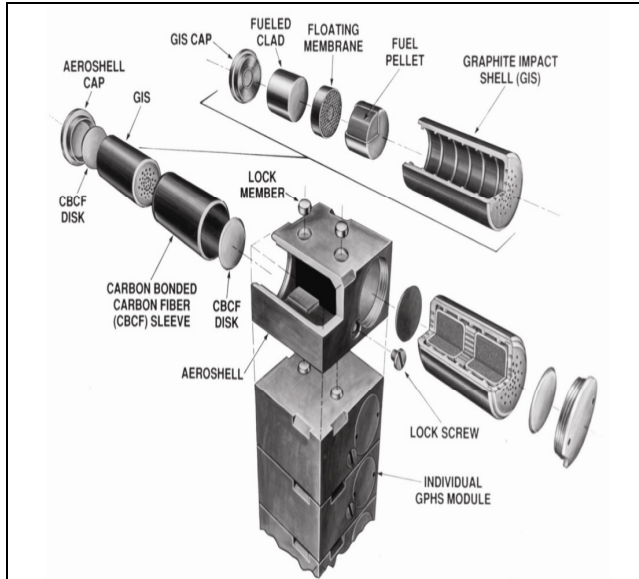

Figure 3: General Purpose Heat Source (GPHS)



Figure 4: RPS Sled Impact Testing



Figure 5: Liquid hydrogen liquid oxygen blast environment test

spacecraft designs, alternate RPS locations can help avoid or limit the potential RPS radioactive releases associated with certain launch intact impact accidents. In the launch phase, several opportunities exist for avoiding or limiting potential accident releases of radioactive materials. Examples specific to the launch area include: enhancing the visibility and telemetry for commanded destruct systems; shortening response times for commanded launch destruct systems; and adding redundant and automated launch vehicle destruct systems. All of these examples help limit the potential crushing forces and fire hazards associated with the intact impact of the entire flight system (i.e. launch vehicle and its RPS application payload). Examples specific to locations downrange from the launch site include: increasing the likelihood of spacecraft control in on-orbit or post-injection anomalies; and deploying ground-commanding resources for increasing the likelihood of spacecraft control in on-orbit anomalies. Both of these examples enhance a mission’s likelihood of mitigating on-orbit anomalies that could result in uncontrolled reentry and ground impact of an RPS application. Examples relevant to science missions involving Earth swingby (i.e. gravity assist) trajectories include: minimizing operations during critical maneuvers; and biasing Earth swingby trajectories away from Earth. The first example helps limit the likelihood of having an anomaly that could pose the risk of Earth impact while the second example limits the likelihood that any anomaly could result in an Earth impact.

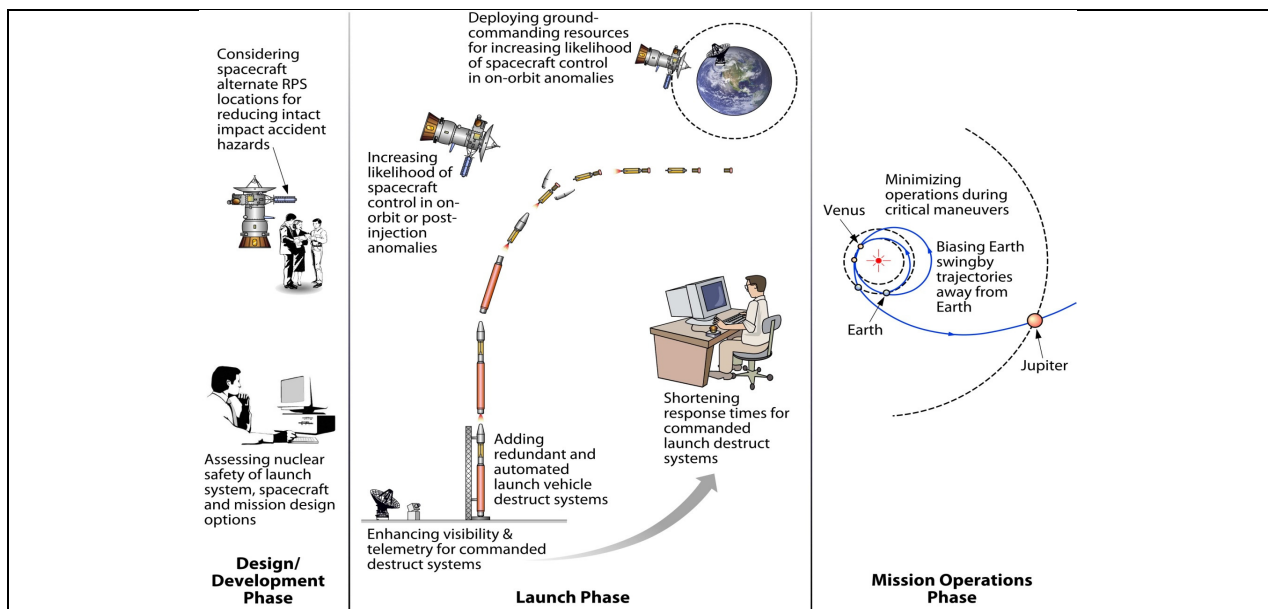

Figure 6: Nuclear Safety Considerations in Space RPS Applications

Nuclear Safety Lessons Learned from NASA Space RPS Missions

Over the last 50 years, the USA has continuously improved its RPS nuclear safety designs and design and development processes based on conducting 29 space RPS application missions, experiencing three RPS application failures, conducting hundreds of accident environment definition and RPS safety tests, implementing new and improved risk assessment modeling methods and technology, and benefiting from the general advances in aerospace and nuclear engineering technology developments and system applications. After the development/implementation of each RPS application, NASA collects “lessons-learned” to document for future potential RPS applications ‘mistakes’ and ‘successes’ relevant to the effective implementation of nuclear launch

safety review processes. Key lessons-learned relevant to designing and developing safe NPS applications include the following:

- *Develop accident scenarios in partnership with RPS, spacecraft and launch vehicle developers/providers.* This provides a means for understanding the contribution of each RPS application component to accident scenarios that threaten RPS fuel containment and provides an objective basis for evaluating potential nuclear safety enhancements.
- *Conduct coordinated rigorous nuclear launch safety analyses, reviews and evaluations with agencies involved in the launch authorization process.* This provides a common database of information for the launch nuclear safety authorization process.
- *Recognize that each spacecraft/launch vehicle configuration is unique.* Achievable risk reductions are not always predictable. All configurations and potential safety enhancements require rigorous analysis.
- *Support a 'safety culture' by creating incentives to continually assess and consider implementation of safety enhancements.* As mentioned above, NASA and DOE have facilitated this by including 'nuclear safety' elements in all major reviews for a proposed or planned RPS application, and by establishing and integrating the nuclear safety risk analysis team into the entire design and development process for an RPS application. (Invariably, conducting detailed risk analyses promotes an understanding of accident scenarios at a level where risk mitigation options can be defined and evaluated.) Further, independent evaluation of NASA/DOE RPS application safety analyses coupled with the Office of the President having responsibility for launch nuclear safety authorization creates a strong and sustained incentive to reduce nuclear risk. If the process had to rely simply on producing an analysis that indicated compliance with a pre-defined 'acceptable' level of safety, incentives to sustain efforts to enhance safety would be limited once the organization conducting the RPS application believed that they had reached the 'acceptable' level. Moreover, given the significant uncertainty and variability in accident risk estimates and the typically unique character of space RPS science applications, it would be impractical to rely strictly on pre-defined 'acceptable' levels of safety. By continuously reviewing the nuclear safety of a planned RPS application throughout its design and development phase, subjecting nuclear safety assessments to independent review, and vesting final nuclear launch safety authorization in the highest office of the government, strong incentives exist for working continuously to reduce nuclear safety risk throughout all phases of an RPS application.

Conclusion

Consistent with the entire scope of guidance in the UN/IAEA Safety Framework, the USA has effectively integrated safety into the design, development and operation of RPS applications by mandating nuclear safety review and approval processes that encompass all the phases, components and participants of a proposed/planned RPS application, and by supporting these processes with rigorous risk assessments and the 'lessons learned' from previous RPS applications.

References

1. Safety Framework for Nuclear Power Source Applications in Outer Space, Jointly Published by the United Nations Committee on the Peaceful Uses of Outer Space Scientific and Technical Subcommittee and the International Atomic Energy Agency, 2009, A/AC.105/934, <http://www.iaea.org/Publications/Booklets/Safety/safetyframework1009.pdf>
2. National Response Framework: Nuclear Radiological Annex, United States Department of Homeland Security, June 2008, NUC-1, http://www.fema.gov/pdf/emergency/nrf/nrf_nuclearradiologicalincidentannex.pdf
3. NASA Procedural Requirements, NPR 8715.3C, Chapter 6, "Nuclear Safety for Launching of Radioactive Materials", http://nodis3.gsfc.nasa.gov/displayDir.cfm?Internal_ID=N_PR_8715_003C_&page_name=Chapter6



Safety in the Design and Development of United States Space NPS Applications

Presented by Reed Wilcox
Jet Propulsion Laboratory, California Institute of Technology

February 2011

(c) 2010 California Institute of Technology. Government sponsorship acknowledged. This research was carried out at the Jet Propulsion Laboratory, California Institute of Technology, under a contract with the National Aeronautics and Space Administration.

December 7, 2010

1



Topics

- ◆ History of United States of America (USA) Space NPS Applications
- ◆ Comparison of UN/IAEA Safety Framework with NASA's Nuclear Safety Implementation for Space Radioisotope Power System (RPS) Applications
- ◆ USA Nuclear Safety Design/Development Requirements for Space Radioisotope Power Systems (RPS) Applications
- ◆ Implementation of Nuclear Safety in NASA Space RPS Applications
- ◆ Nuclear Safety Lessons Learned from NASA Space RPS Applications

December 7, 2010

2



U.S. Nuclear Safety Design/Development Requirements for Space RPS Mission Applications

- ◆ Basic designs of vehicles, spacecraft, and systems utilizing radioactive materials provide protection to the public, the environment, and users such that radiation risk resulting from exposures to radioactive sources are as low as reasonably achievable
- ◆ Nuclear safety considerations are incorporated from the initial design stages throughout all project stages to ensure that overall mission radiological risk is acceptable
- ◆ All space flight equipment (including medical and other experimental devices) that contain or use radioactive materials are identified and analyzed for radiological risk
- ◆ Site-specific ground operations and radiological contingency plans are developed commensurate with the risk represented by the planned launch of nuclear materials
- ◆ Radiological contingency planning includes provisions for emergency response and support for source recovery efforts

December 7, 2010

5



Implementation of Nuclear Safety in NASA Space RPS Applications

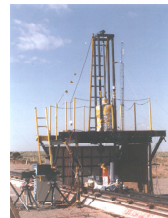
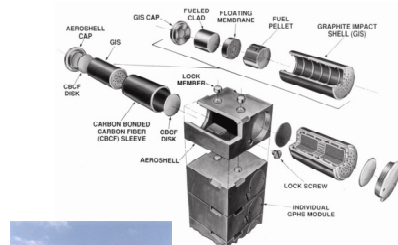

- ◆ Radioisotope Power System (RPS) development programs establish component and system level safety objectives, requirements and performance specifications
 - Radioisotope fuel element designs emphasize containment and immobilization under a wide range of normal and accident conditions (e.g. launch pad explosions, solid and liquid propellant fires, shrapnel impacts, ground impact, reentry)
 - RPS designs include accident performance specifications that maximize the safety benefits of element containment/immobilization designs
 - Safety testing and analysis programs verify safety designs

December 7, 2010

6

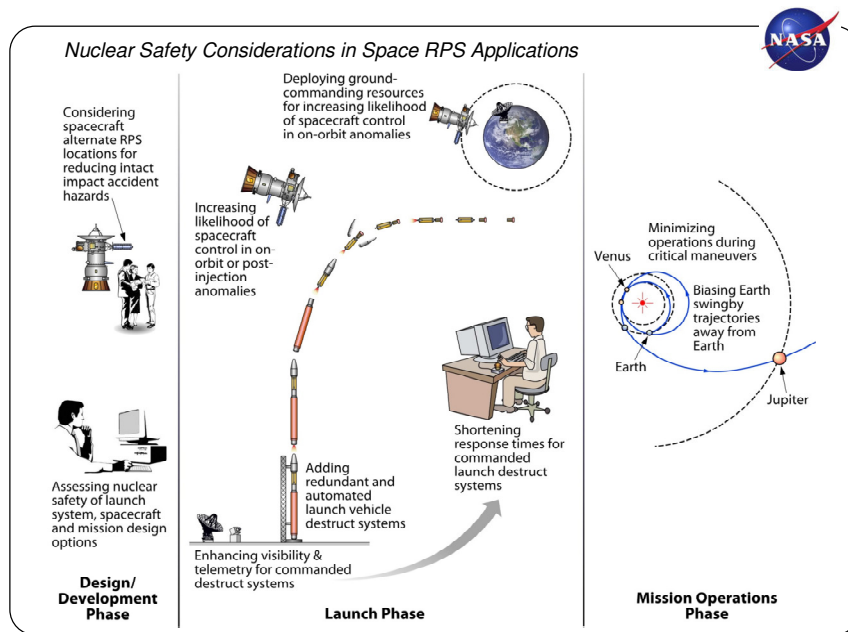

December 7, 2010

7

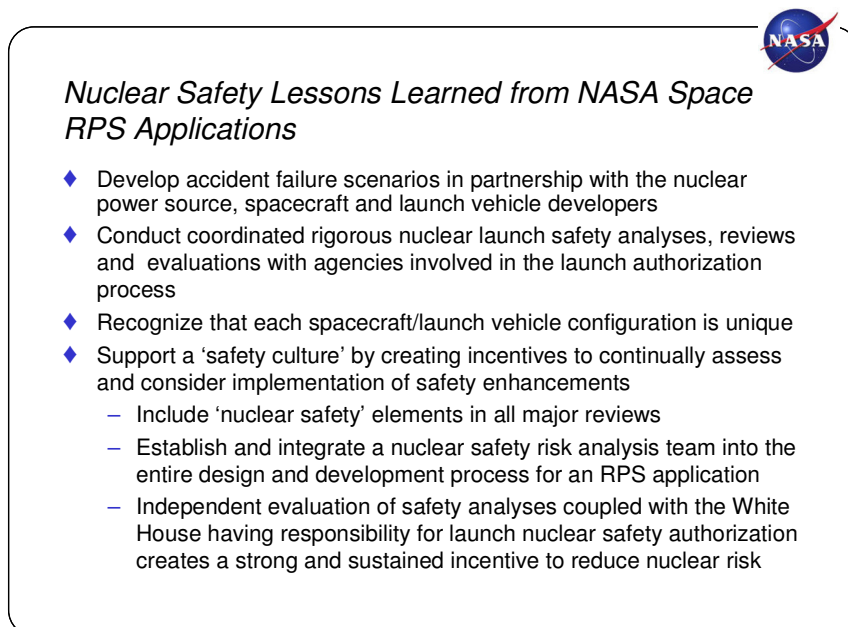

December 7, 2010

8